

HIGH PERFORMANCE  
**MARITIME**  
PRODUCTS

# em-trak B200

## AIS Class B Transceiver



## Product Manual



[www.em-trak.com](http://www.em-trak.com)

---

# Table of contents

<b>1 Notices</b> .....	<b>1</b>
1.1 Safety warnings .....	1
1.2 General notices .....	1
<b>2 About your AIS class B transceiver</b> .....	<b>3</b>
2.1 About AIS .....	3
2.2 Static and dynamic vessel data .....	3
2.3 Important information for US customers .....	4
2.4 What's in the box? .....	5
<b>3 Installation</b> .....	<b>7</b>
3.1 Preparing for Installation .....	7
3.2 Installation procedures .....	9
<b>4 Configuring your AIS transceiver</b> .....	<b>15</b>
4.1 Switching on your AIS transceiver for the first time .....	15
4.2 Introduction to the proAIS software .....	16
4.3 Installing the proAIS software .....	16
4.4 Configuration using proAIS .....	17
<b>5 Operation</b> .....	<b>19</b>
5.1 Using the AIS transceiver .....	19
5.2 Switch functions .....	19
5.3 Using proAIS with your AIS transceiver .....	20
5.4 Indicator functions .....	23
<b>6 Troubleshooting</b> .....	<b>24</b>
<b>7 Specifications</b> .....	<b>25</b>

# Table of figures

Figure 1	Items included in the product.....	5
Figure 2	AIS transceiver overview .....	6
Figure 3	Electrical connections to the AIS transceiver .....	6
Figure 4	Typical installation configuration.....	7
Figure 5	AIS transceiver dimensions .....	10
Figure 6	AIS transceiver mounting .....	10
Figure 7	GPS antenna mounting .....	11
Figure 8	Position of the GPS antenna connector .....	11
Figure 9	Position of the VHF antenna connector.....	12
Figure 10	Connecting an external switch.....	12
Figure 11	Connecting to the NMEA0183 data port.....	13
Figure 12	Connecting the power supply .....	14
Figure 13	Indicator start up sequence .....	15
Figure 14	Entering static data into proAIS .....	16
Figure 15	proAIS GPS status page .....	20
Figure 16	proAIS Diagnostics page .....	21
Figure 17	proAIS Other vessels page.....	21
Figure 18	proAIS Messages page .....	22
Figure 19	proAIS Serial data page .....	22
Figure 20	Indicator location on the AIS transceiver unit .....	23

---

# 1 Notices



When reading this manual please pay attention to warnings marked with the warning triangle shown on the left. These are important messages for safety, installation and usage of the product.

## 1.1 Safety warnings



This equipment must be installed in accordance with the instructions provided in this manual.



This equipment is intended as an aid to navigation and is not a replacement for proper navigational judgement.



Do not install this equipment in a flammable atmosphere such as in an engine room or near to fuel tanks.

## 1.2 General notices

### Position source

All marine Automatic Identification System (AIS) transceivers utilise a satellite based location system such as the Global Positioning Satellite (GPS) network.

The accuracy of a GPS position fix is variable and is affected by factors such as the antenna positioning, how many satellites are used to determine a position and how long satellite information has been received for.

### Compass safe distance

The compass safe distance of this unit is 0.5m or greater for 0.3° deviation.

### RF emissions notice

Caution: The AIS transceiver generates and radiates radio frequency electromagnetic energy. This equipment must be installed and operated according to the instructions contained in this manual. Failure to do so can result in personal injury and / or AIS transceiver malfunction.

Caution: Never operate the AIS transceiver unless it is connected to a VHF antenna.

To maximise performance and minimise human exposure to radio frequency electromagnetic energy you must make sure that the antenna is mounted at least 1.5 meters away from the AIS transceiver and is connected to the AIS transceiver before power is applied. The system has a Maximum Permissible Exposure (MPE) radius of 1.5m. This has been determined assuming the maximum power of the AIS transceiver and using antennas with a maximum gain of 3dBi. The antenna should be mounted 3.5m above the deck in order to meet RF exposure requirements. Higher gain antennas will require a greater MPE radius. Do not operate the unit when anyone is within the MPE radius of the antenna (unless they are shielded from the antenna field by a grounded metallic barrier).

The antenna should not be co-located or operated in conjunction with any other transmitting antenna.

The required antenna impedance is 50 ohms.

## Warranty

This product is supplied with standard warranty as defined in the accompanying warranty information.



**Any attempt to tamper with or damage this product will invalidate the warranty.**

## Disposal of this product and packaging

Please dispose of the AIS transceiver in accordance with the European WEEE Directive or with the applicable local regulations for disposal of electrical equipment.

Every effort has been made to ensure the packaging for this product is recyclable. Please dispose of the packaging in an environmentally friendly manner.

## Accuracy of this manual

The AIS transceiver may be upgraded from time to time and future versions of the AIS transceiver may therefore not correspond exactly with this manual. Information contained in this manual is liable to change without notice. The manufacturer of this product disclaims any liability for consequences arising from omissions or inaccuracies in this manual and any other documentation provided with this product.

## Declaration of conformity

The manufacturer of this product declares that this product is in compliance with the essential requirements and other provisions of the R&TTE directive 1995/5/EC.

The product carries the CE mark, notified body number and alert symbol as required by the R&TTE directive.

The product is intended for sale in the following member states: Great Britain, France, Spain, Sweden, Austria, Netherlands, Portugal, Denmark, Norway, Belgium, Italy, Finland, Ireland, Luxembourg, Germany, Czech Republic.

## FCC notice

This equipment has been tested and found to comply with the limits for a class B digital device, pursuant to part 15 of the FCC Rules. These limits are designed to provide reasonable protection against harmful interference in a residential installation.

This equipment generates, uses and can radiate radio frequency energy and, if not installed and used in accordance with the instructions, may cause harmful interference to radio communications.



**WARNING: It is a violation of the rules of the Federal Communications Commission to input an MMSI that has not been properly assigned to the end user, or to otherwise input any inaccurate data in this device.**

## Industry Canada notice

This AIS class B digital apparatus complies with Canadian ICES-003.

Cet appareil numérique de la AIS classe B est conforme à la norme NMB-003 du Canada.

## 2 About your AIS class B transceiver

### 2.1 About AIS

The marine Automatic Identification System (AIS) is a location and vessel information reporting system. It allows vessels equipped with AIS to automatically and dynamically share and regularly update their position, speed, course and other information such as vessel identity with similarly equipped vessels. Position is derived from the Global Positioning System (GPS) and communication between vessels is by Very High Frequency (VHF) digital transmissions.

There are a number of types of AIS device as follows:

- **Class A transceivers.** These are similar to class B transceiver, but are designed to be fitted to large vessels such as cargo ships and large passenger vessels. Class A transceivers transmit at a higher VHF signal power than class B transceivers and therefore can be received by more distant vessels, and also transmits more frequently. Class A transceivers are mandatory on all vessels over 300 gross tonnes on international voyages and certain types of passenger vessels under the SOLAS mandate.
- **Class B transceivers.** Similar to class A transceivers in many ways, but are normally lower cost due to the less stringent performance requirements. Class B transceivers transmit at a lower power and at a lower reporting rate than class A transceivers.

- **AIS basestations.** AIS basestations are used by Vessel Traffic Systems to monitor and control the transmissions of AIS transceivers.
- **Aids to Navigation (AtoN) transceivers.** AtoNs are transceivers mounted on buoys or other hazards to shipping which transmit details of their location to the surrounding vessels.
- **AIS receivers.** AIS receivers will generally receive transmissions from class A transceivers, class B transceivers, AtoNs and AIS basestations but do not transmit any information about the vessel on which they are installed.

### 2.2 Static and dynamic vessel data

There are two categories of information transmitted by an AIS transceiver: static and dynamic data.

The vessel's dynamic data, which includes location, speed over ground (SOG) and course over ground (COG), is calculated automatically using the internal GPS receiver.

Static data is information about the vessel which must be programmed into the AIS transceiver. This includes:

- Maritime Mobile Service Identity (MMSI)
- Vessel name
- Vessel call sign (if available)
- Vessel type
- Vessel dimensions

In most countries the operation of an AIS transceiver is included under the vessel's marine VHF licence provisions. The vessel on to

which the AIS unit is to be installed must therefore possess a current VHF radiotelephone licence which lists the AIS system, vessel Call Sign and MMSI number.



**An MMSI number is required in order for the AIS transceiver to operate. Please contact the relevant authority in your country for more information.**

## **2.3 Important information for US customers**

There are specific laws in the USA regarding the configuration of AIS class B transceivers.

If you are a US resident and intend to use your AIS class B transceiver in US waters, you should make sure that your retailer has configured your product prior to supplying it to you. If your AIS transceiver has not been pre-configured please contact your dealer for details of how to have it configured.



**In the United States of America, the MMSI and static data must only be entered by a competent installer. The end user of the equipment is not authorised to enter their own static data.**

## 2.4 What's in the box?

Figure 1 shows the items included with your AIS transceiver purchase. The following sections give a brief overview of each item. Please ensure all items are present and if any of the items are not present contact your dealer.

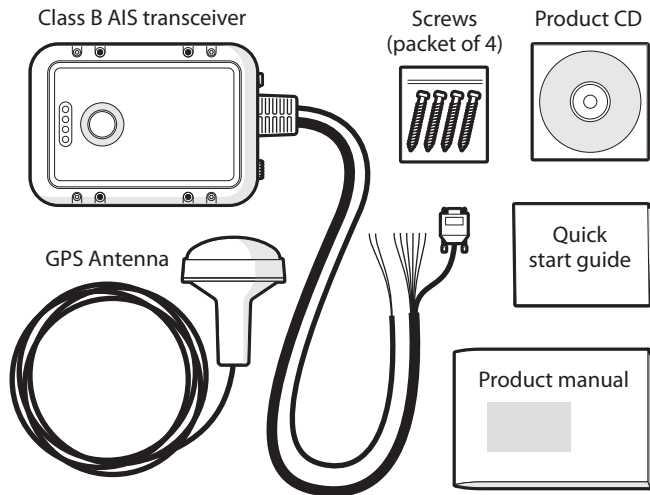

Figure 1 Items included in the product

- Support tools CD

The CD supplied with the package contains the proAIS software tool necessary to configure the AIS transceiver. Please refer to section

4 for details of the configuration process and how to use the proAIS tool.

- Quick start guide

The quick start guide gives a handy one page reference for the installation process.

- Product manual

This document is the product manual and should be read thoroughly prior to any attempt to install or use the AIS transceiver.

- GPS antenna

The GPS antenna forms an integral part of the product's internal positioning system based on GPS. Please refer to section 3.2 for details of how to install the GPS antenna.

- Fixing screws

Four fixing screws are provided with the product for mounting of the AIS transceiver. Please refer to section 3.2 for details of how to mount the AIS transceiver.

- AIS transceiver unit

Figure 2 shows an overview of the AIS transceiver unit.

The AIS transceiver has a number of indicators which provide information to the user about the status of the AIS transceiver. Please refer to section 5.4 for more details of indicator functions.

The AIS transceiver has a single switch which can be configured to provide certain functions as defined in section 5.2.

Figure 2 shows the AIS transceiver mounting holes. Please refer to section 3.2 for details of how to mount the AIS transceiver.



**Do not attempt to adjust or remove the fixings next to each of the four mounting holes. These fixings form part of the sealing of the AIS transceiver and any modification could affect the product's performance and will invalidate the product's warranty.**

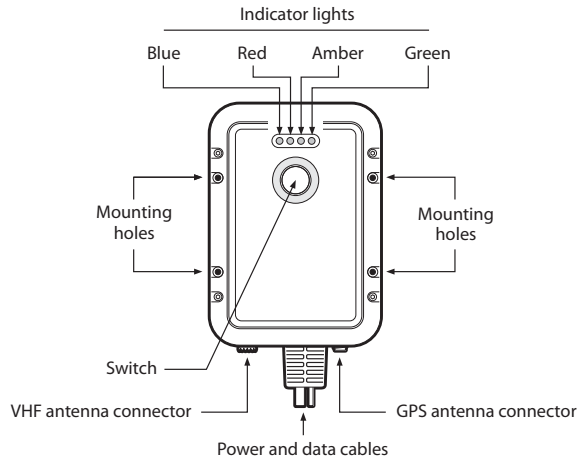

Figure 2 AIS transceiver overview

## Electrical connections

The AIS transceiver has the following connections provided by the attached cables:

- Power supply
- NMEA0183 data port for connection to chart plotters
- RS232 for connection to a PC
- External switch input

In addition there are two other connections for the GPS antenna and the VHF antenna.

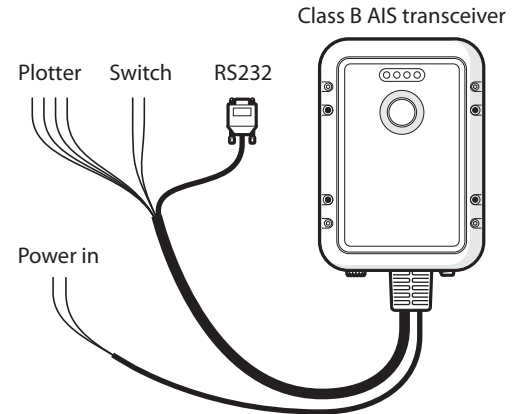

Figure 3 Electrical connections to the AIS transceiver

## 3 Installation

### 3.1 Preparing for Installation

Figure 4 shows a typical installation configuration for the AIS transceiver. Please take the time to familiarise yourself with the system elements and their connections prior to attempting installation.

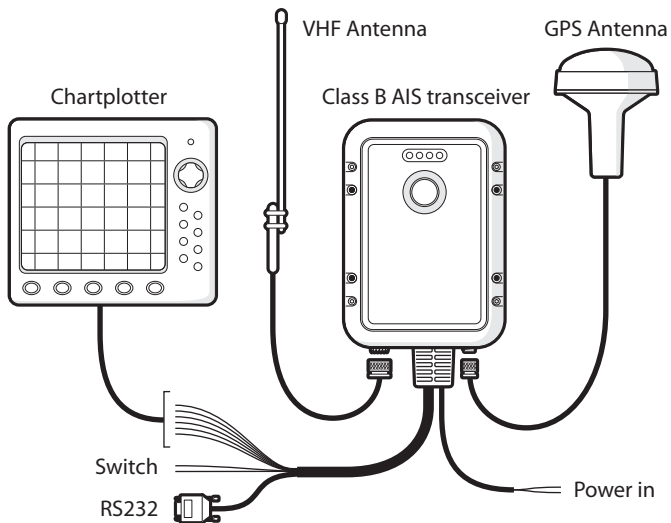

Figure 4 Typical installation configuration

In addition to the items provided with your AIS transceiver the following items will be required for installation:

#### VHF antenna

Connection to a suitable VHF antenna will be required for the AIS transceiver to operate. A standard marine band VHF antenna such as that used with VHF voice radios will be sufficient. Please take note of the warnings in section 1 regarding the use of antennas.

Alternatively, if you wish to use an existing VHF antenna, antenna splitter products are available which allow the existing antenna to be used with two radio devices, such as a VHF voice radio and the AIS transceiver.



**When selecting an AIS antenna splitter make sure it is capable of operation with an AIS transceiver. Some AIS antenna splitters are designed to work only with AIS receivers. Please check with your dealer to ensure you purchase the correct type of antenna splitter.**

#### Antenna cables

The GPS antenna is provided with 10 metres of cable. If this is not sufficient to reach between the desired GPS antenna location and the AIS transceiver unit you will need an extension cable. Please contact your dealer for details. For reference the GPS antenna connector type on the AIS transceiver unit is TNC receptacle, and is intended to mate with a TNC jack connector.

Please check that the VHF antenna you intend to use has sufficient cable to reach between the VHF antenna and the AIS transceiver unit. If it is not sufficient you will need an extension cable. Please contact your dealer for details of suitable products. For reference the VHF antenna connector type on the AIS transceiver unit is SO 239, and is intended to mate with a PL 259 connector.

### **Power and data cables**

The AIS transceiver unit is supplied with a one metre long power and data cable as an integral part of the AIS transceiver unit. If you require longer cables to reach your power supply, please ensure the cables are capable of carrying currents of up to 2A peak and 500mA on average. Means of connecting the cables together will also be required. The use of Scotchlok™ connectors is recommended for this purpose.

### **Chart plotter**

To display received AIS messages as other vessels on your chart plotter, you will need to connect your AIS transceiver to your chart plotter. Please refer to the user manual supplied with your chart plotter for details of how to connect and configure your chart plotter for use with AIS devices. For general guidance your chart plotter should be configured to accept NMEA data at 38400 baud (sometimes referred to as 'NMEA HS' in the plotter configuration menu). You may also need to enable the display of AIS targets in the chart options.

### **Connection to a PC**

If you choose to use a PC with suitable charting software to display received AIS messages as other vessels, this can be accomplished

by connecting the RS232 directly to the PC, or via a suitable RS232 to USB converter if your PC does not have a RS232 port.

### **GPS antenna mount**

A one inch 14 TPI pole mount is required to mount the supplied GPS antenna. Please contact your dealer for details of suitable products.

## 3.2 Installation procedures

Before beginning installation of your AIS transceiver, please ensure you have the necessary additional items as detailed in section 3.1. It is strongly recommended that you read all of the instructions in this manual prior to installation.

If after reading this manual you are unsure about any element of the installation process please contact your dealer for advice.

The following sections explain the installation process step by step for each of the main elements of the system.

### Step 1 - Installing the AIS transceiver

Please note the following guidelines when selecting a location for your AIS transceiver:

- The AIS transceiver must be fitted in a location where it is at least 0.5m from a compass or any magnetic device.
- There should be adequate space around the AIS transceiver for routing of cables. See Figure 5 for details of the AIS transceiver dimensions.
- The ambient temperature around the AIS transceiver should be maintained between -10°C and +55°C.
- The AIS transceiver should not be located in a flammable or hazardous atmosphere such as in an engine room or near to fuel tanks.
- The AIS transceiver is fully waterproof to ingress protection rating IPx7, however it is recommended that the AIS transceiver is not subjected to extended periods of exposure to spray or submersion.

- It is recommended that the AIS transceiver is installed in a 'below decks' environment.
- It is acceptable to mount the AIS transceiver either vertically or horizontally.
- The product is supplied with four self tapping screws for attachment of the AIS transceiver to a suitable surface. Please refer to Figure 6 for guidance.
- The AIS transceiver should be mounted in a location where the indicators are readily visible as these provide important information on the status of the AIS transceiver.

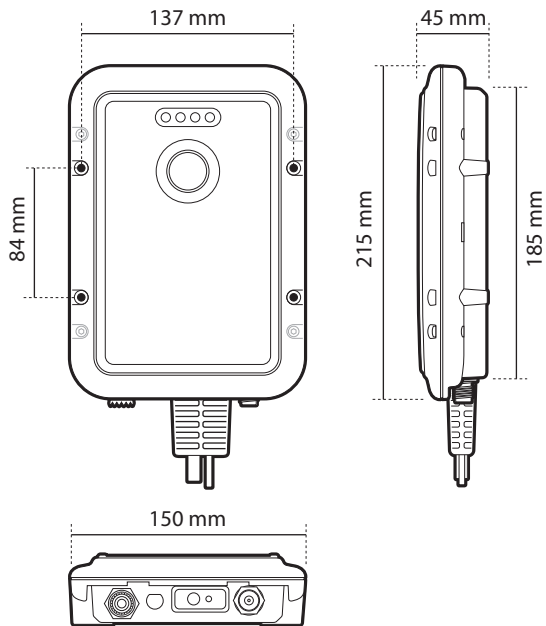

Figure 5 AIS transceiver dimensions

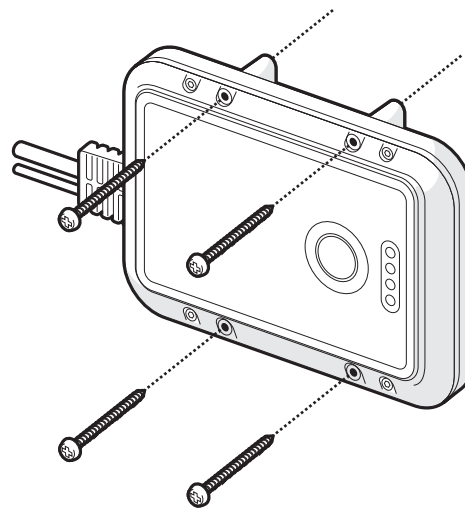

Figure 6 AIS transceiver mounting

## Step 2 - Installing the GPS antenna

For mounting of the GPS antenna provided with your AIS transceiver you will require a one inch 14 TPI thread pole.

You should ensure the GPS antenna has a good clear view of the entire sky.

It is not recommended that the GPS antenna is mounted up a mast where the motion of the vessel will cause the antenna to swing and potentially reduce the accuracy of the GPS position.

Do not mount your antenna in the direct path of a radar transmitter.

Feed the ten metre long cable attached to the GPS antenna cable through the pole and screw the antenna onto the pole mount as shown in Figure 7.

Route the cable to your AIS transceiver unit, adding any necessary extension cables.

Connect the cable from the GPS antenna to the GPS connector on the AIS transceiver as shown in Figure 8.

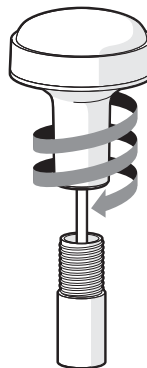

Figure 7 GPS antenna mounting

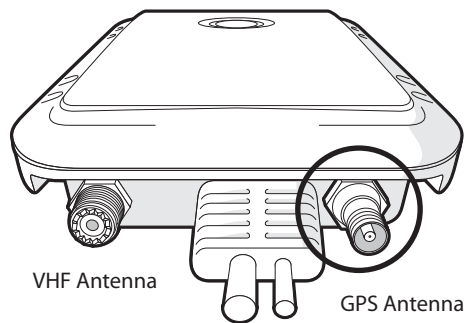

Figure 8 Position of the GPS antenna connector

### Step 3 - Connecting the VHF antenna

Route the cable from the VHF antenna to the AIS transceiver and connect to the VHF connector on the AIS transceiver as shown in Figure 9.

A standard marine band VHF antenna or AIS antenna should be used with the AIS transceiver. The connector type on the AIS transceiver is SO239. Your chosen VHF antenna requires a PL259 connector to mate with this. If your VHF antenna does not use this type of connector please contact your dealer for details of available adaptors.

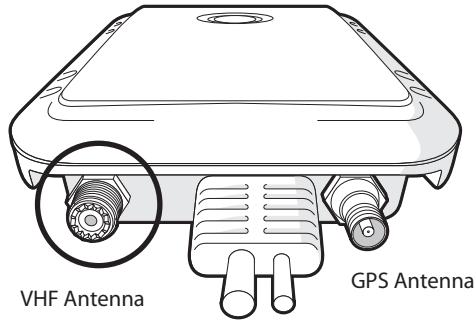

Figure 9 Position of the VHF antenna connector

### Step 4 - Connecting an external switch

If you require a remote external switch to activate the silent mode feature, it is possible to connect a toggle switch to the AIS transceiver and configure the switch function accordingly.

Connect the toggle switch between the orange and blue wires as shown in Figure 10 and configure the switch function in proAIS to 'Make switch to disable transmitter'. For more details on how to do this please refer to section 4.4.

Connection of an external switch to toggle silent mode is optional and not essential for normal operation of the product.

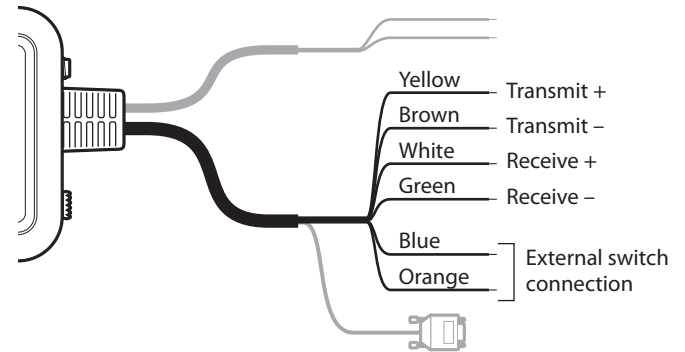

Figure 10 Connecting an external switch

## Step 5 - Connecting to a chart plotter

The NMEA0183 data port provides the connection to your chart plotter and consists of four wires colour coded as shown in the table below and in Figure 11. Connect the wires to the appropriate connections on your chart plotter. Please refer to your chart plotter manual for more information.

The NMEA0183 data port operates at a baud rate of 38400. Please ensure your chart plotter is configured to receive data from the AIS transceiver via its NMEA0183 port at 38400 baud.

Please note that the 'Receive' connections may not be needed when connecting to your chart plotter as it is not normal for the transceiver to receive data from the chart plotter.

NMEA0183 function	Wire colour
Transmit +	Yellow
Transmit -	Brown
Receive +	White
Receive -	Green

### Connecting an optional NMEA0183 device

If you wish to connect a NMEA0183 device (such as a heading sensor) to your chart plotter, but your chart plotter only has a single NMEA0183 input, it is possible to use the AIS transceiver's NMEA0183 multiplexing feature to connect both devices to the chart plotter.

To multiplex your NMEA0183 device data via the AIS transceiver simply connect the device's NMEA0183 output to the receive+ and receive- terminals as defined in the table above. Follow the instructions in section 4.4 to configure the AIS transceiver to multiplex the devices NMEA0183 data to your chart plotter.

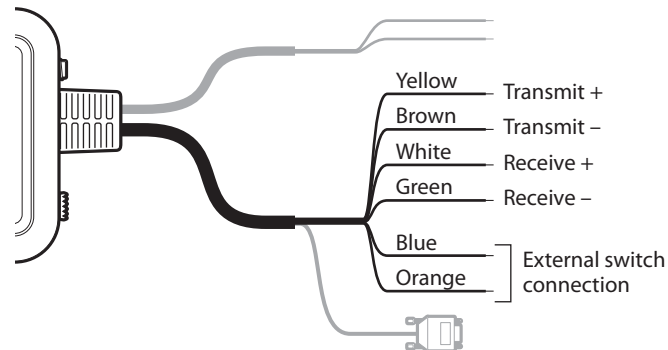

Figure 11 Connecting to the NMEA0183 data port

### Connection to a PC

The AIS transceiver is supplied with an RS232 port for connection to a PC. The RS232 connector can be connected directly to the RS232 port on the PC or via a serial to USB converter if no RS232 port is available. For configuration of the AIS transceiver it is necessary to connect to a PC if your AIS transceiver has not been pre-configured by your dealer. See section 4 for more details of configuration.

## Step 6 - Connecting to a power supply

The AIS transceiver requires a 12V power supply typically provided by the vessel's battery.



**Do not use a 24V power supply with the AIS transceiver. Should a 24V supply be connected to the AIS transceiver, an internal protection system will be invoked and the AIS transceiver will not operate as normal. However, no permanent damage will be caused to the AIS transceiver. The AIS transceiver will operate as normal once connected to a 12V power supply.**

It is recommended that crimped and soldered lugs are used to connect the AIS transceiver to the power source.

It is recommended that the power supply is connected via a suitable circuit breaker and/or 3A fuse block.

1. Connect the red wire to a 12V power supply positive terminal.
2. Connect the black wire to the supply negative terminal.

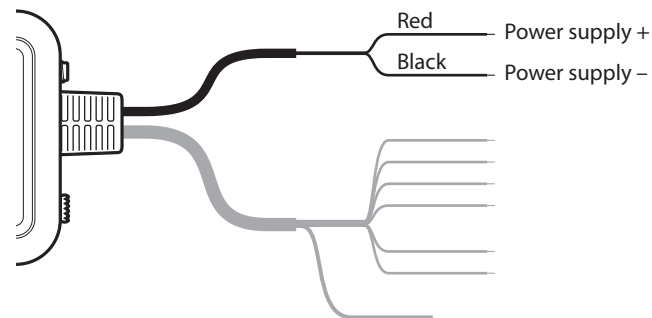

Figure 12 Connecting the power supply

## 4 Configuring your AIS transceiver

### 4.1 Switching on your AIS transceiver for the first time

A few seconds after applying power to the AIS transceiver for the first time all four indicators (green, amber, red and blue) will blink twice. The indicator sequence following this will depend on whether your transceiver is pre-configured.

#### Transceiver is pre-configured:

The amber indicator will illuminate until the transceiver has transmitted an AIS message.

#### Transceiver is not pre-configured:

The amber and red indicator will illuminate. This indicates the unit cannot transmit until it is configured with a valid MMSI.

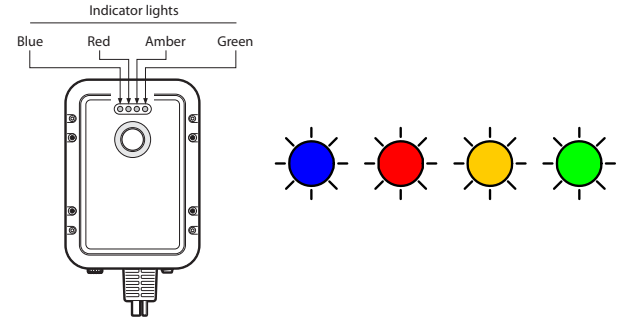

Figure 13 Indicator start up sequence

Prior to use the AIS transceiver requires programming with the vessel's static data to ensure that the data transmitted by the AIS transceiver matches that of the host vessel.



**US Customers only: It is a violation of the rules of the Federal Communications Commission for the end user to programme the static data. The static data must only be programmed by a competent installer. If your AIS transceiver has not been preconfigured for you please refer to your dealer for advice on how to have the AIS transceiver configured by a competent installer.**

## 4.2 Introduction to the proAIS software

Included in the CD supplied with your product is a configuration software tool called 'proAIS'.



**proAIS is only compatible with Windows based operating systems and is not compatible with Apple MAC operating systems.**

proAIS is a software tool which provides the facility to configure, monitor and diagnose issues with your AIS transceiver.

Section 4.3 provides instructions on how to install the proAIS software.

Section 4.4 describes how to use proAIS to configure the static data and other settings for your AIS transceiver.

Section 5.3 describes how to use proAIS to monitor the status of your AIS transceiver.

## 4.3 Installing the proAIS software

This software is designed to be installed and used with a PC connected to the AIS transceiver via the data lead provided as standard with the AIS transceiver unit. If the PC being used for programming does not have a 9-pin serial port then a commercially available USB to serial adaptor may be required. This connects between the supplied data lead and the PC.

To install proAIS on your PC:

1. Locate and run the setup.exe file on the CD and then follow the on-screen prompts.
2. If a security warning appears, click 'Install' to continue with the installation.
3. Once installation is complete, proAIS will launch automatically and a start menu folder and shortcut will be created for future use.
4. Once proAIS has launched you should see a window as shown in Figure 14.
5. Please follow the instructions in section 4.4 to configure your AIS transceiver.

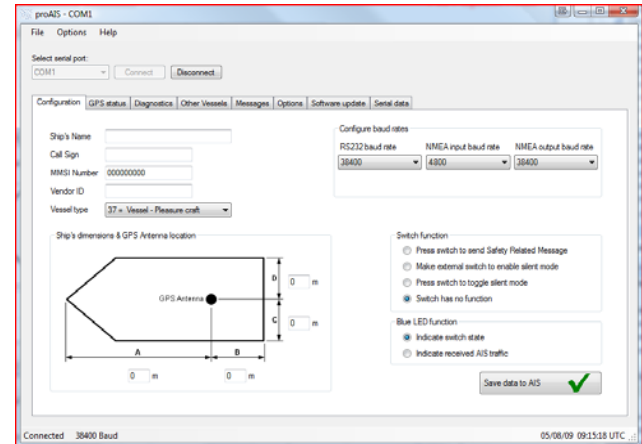

Figure 14 Entering static data into proAIS

## 4.4 Configuration using proAIS



**Please ensure that you enter all static data accurately. Failure to do so could result in other vessels failing to identify your vessel correctly.**



**The vessel MMSI can only be programmed once using proAIS, please take care to programme your MMSI correctly. If you need to change the MMSI for any reason, please contact your dealer who will arrange to have the MMSI reset.**

Follow the steps below to configure the AIS transceiver:

1. Connect your AIS transceiver to the PC using the RS232 lead as described in section 3.2. Apply 12V power to the AIS transceiver as described in section 3.2.
2. Select the appropriate serial port in proAIS and press 'Connect'.
3. proAIS should launch with the 'static data' page active (see Figure 14). If this is not the case please select the 'static data' page.
4. Carefully enter the data fields on the screen including:
  - MMSI - the vessel's MMSI must be 9 digits in length and should be the same as that used for any other digital radio equipment such as a VHF DSC radio.
  - Ship's name - the ship's name can be up to 20 characters in length.

- Call sign - the call sign can be up to seven characters in length. Not all vessels are issued with a call sign and it is acceptable to leave this field blank.
  - Vessel type - select a vessel type from the drop down list which most closely matches your vessel.
  - GPS antenna location - use the on-screen guide to specify the distances from your GPS antenna to the edges of the vessel as shown. The distances are entered in metres.
5. Select the desired switch from the following options:
    - Press switch to send safety related message.
    - Make switch to disable transmitter (This is required if you intend to use an external toggle switch to control silent mode).
    - Press switch to toggle transmitter on/off (This is required if you intend to use the integrated switch to toggle silent mode).
    - Switch has no function.

Please note: the integrated switch can only provide one of these functions at any one time. If you wish to change the function of the switch please return to this configuration process.

6. Set the blue indicator function.
  - The blue indicator can be configured to show either the status of the switch or to show when AIS messages are being received from other vessels.
  - Note that the blue indicator cannot perform both functions simultaneously.

7. Set the baud rates to the required level for each of the serial ports.
  - Set the RS232 baud rate to the required level. The default is 38,400. This is the baud rate used when communicating with a PC via the RS232 connection.
  - Set the NMEA output (transmit) baud rate to the required level. The default is 38,400. This is the baud rate used when transmitting data to a chart plotter via its NMEA0183 input.
  - Set the NMEA input (receive) baud rate to the required level. The default is 4,800. If you are using an optional NMEA0183 device such as a heading sensor (see section 3.2) please select the baud rate at which the NMEA0183 device is transmitting data. If you are not using an optional NMEA0183 device this baud rate should be set to the same level as the NMEA transmit baud rate.
8. Once all data has been entered correctly, press 'Save static data to AIS unit'. This will permanently store the data to the unit.
9. You will see a pop-up window warning you that the MMSI can only be entered once and should therefore be entered correctly. Please double check you have entered the correct MMSI.
10. All other static data can be modified by repeating the steps above.
11. If you need to change the MMSI for any reason please contact your dealer who will be able to reset the unit.

# 5 Operation

## 5.1 Using the AIS transceiver

Once the unit has been configured it is ready for use. Providing other vessels with AIS transceivers installed are within radio range of your vessel you should see their details appear on your chart plotter or PC. These vessels will also be able to see your vessel on their chart plotter or PC. It may take up to six minutes for your full vessel details to be visible to others.

Specific details of how to configure your chart plotter to make use of the AIS transceiver features will be given in your chart plotter manual. If you are using charting software running on a PC, please refer to the instructions provided with your chart plotting software for details of how to configure it to display AIS information.

## 5.2 Switch functions

The integrated switch on the top of the unit (see Figure 2) can be configured either to trigger transmission of a "Safety Related Message" or to place the unit into "Silent mode". This choice is made during configuration of the unit using the proAIS application; please refer to 4.4 for further information on the configuration options.

### Safety related message

When configured to transmit a safety related message (SRM) the switch will initiate broadcast of an AIS message containing the vessels MMSI along with the text "MAYDAY MAYDAY". The switch

must be pressed for at least two seconds to initiate this transmission (to avoid accidental activation) and the blue indicator will illuminate to indicate the message has been sent. Further safety related messages cannot be sent until the blue indicator has extinguished which will occur one minute after an SRM has been sent.



**The SRM function is not a primary means of distress call and cannot be relied upon as a means of distress call.**

### Silent mode

When configured to place the unit into "Silent mode", each press of the switch will toggle the AIS transmitter on or off. The switch must be depressed for two seconds to activate silent mode to avoid accidental activation. When the transmitter is off, the amber and blue indicators will be illuminated and the AIS transceiver's position will not be broadcast to other vessels. The position of other vessels will still be received by the unit.

Silent mode can be used if you wish to only receive AIS messages from other vessels but keep your own details private from other AIS users.



**Your vessel will not be displayed on other users, chart plotters or PCs while your AIS transceiver is in silent mode.**

## 5.3 Using proAIS with your AIS transceiver

The proAIS tool has a range of features to help monitor the performance of your AIS transceiver. To use the full range of features your AIS transceiver must be installed as described in section 3 and connected to a PC running the proAIS application.

### proAIS menus

This section describes the functions available via the proAIS menus.

The proAIS 'File' menu includes the following functions:

**Open log file** - this includes the ability to open a log file previously captured using the log file capture tool.

The proAIS 'Options' menu includes the following functions:

**Beep on AIS transmission** - the PC will make an audible beep when an AIS message is transmitted.

**Force connection** - forces proAIS to make a connection with the AIS unit even when no response is received from the unit.

The proAIS 'Help' menu includes the following functions:

**About** - details of the version number of the proAIS software you have installed.

### proAIS GPS status page

The 'GPS status' page shows the signal strength of each satellite being received and the dynamic data of the vessel. Satellite signals shown as green bars are actively being used to calculate a position fix. If a position fix cannot be achieved then no dynamic data will be shown and all signal strength bars will be blue.



Figure 15 proAIS GPS status page

## proAIS Diagnostics page

The 'Diagnostics' page provides a range of information about the AIS transceiver's status. Referring to the information in this page may be useful if you are attempting to diagnose a potential issue with the AIS transceiver's installation or operation.

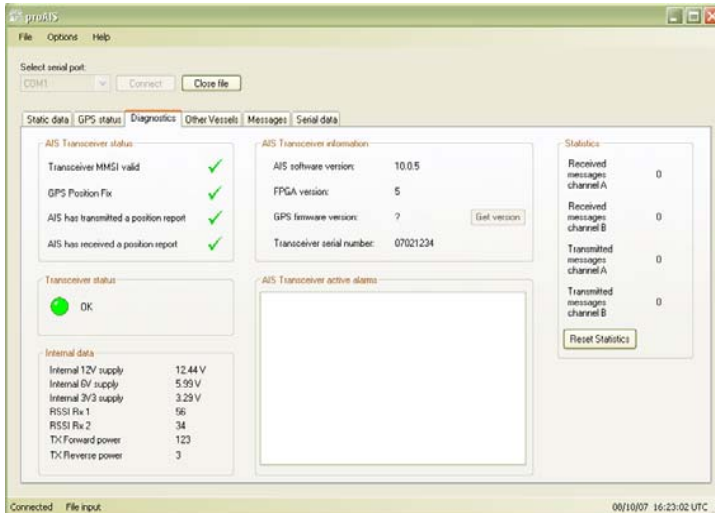

Figure 16 proAIS Diagnostics page

## proAIS Other vessels page

The 'Other vessels' page provides a list of all vessels from which AIS messages are being received. For each vessel the MMSI, name, call sign, speed and course, position, range and bearing are shown if available.

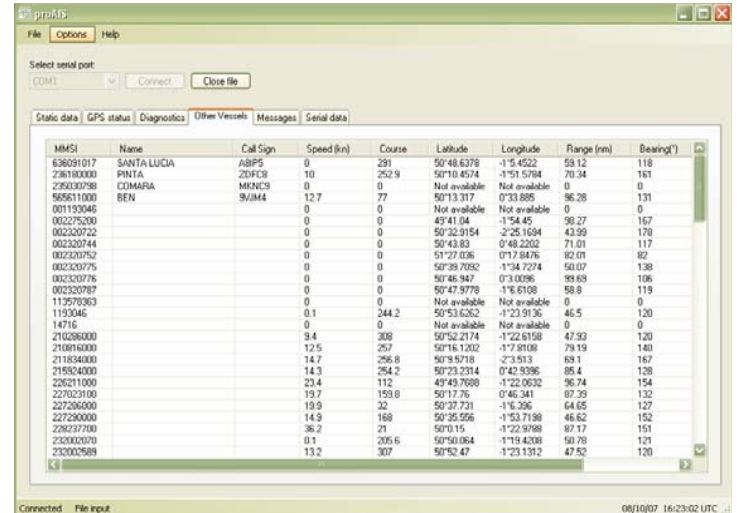

Figure 17 proAIS Other vessels page

## proAIS Messages page

The 'Messages' page provides a list of all text messages received from other vessels. These are most likely to be safety related messages which are requests for assistance from other vessels.

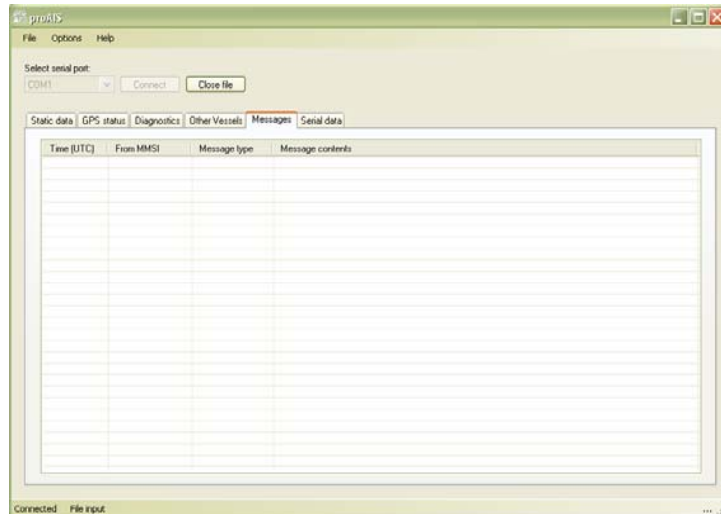

Figure 18 proAIS Messages page

## proAIS Serial data page

The 'Serial data' page provides a view of all incoming and outgoing AIS messages. The messages are encoded in a special format and it is not necessary to understand the meaning of the messages to use the equipment. The serial data page includes the facility to capture your AIS data during a journey and then play it back using the 'open log file' command in the 'File' menu.

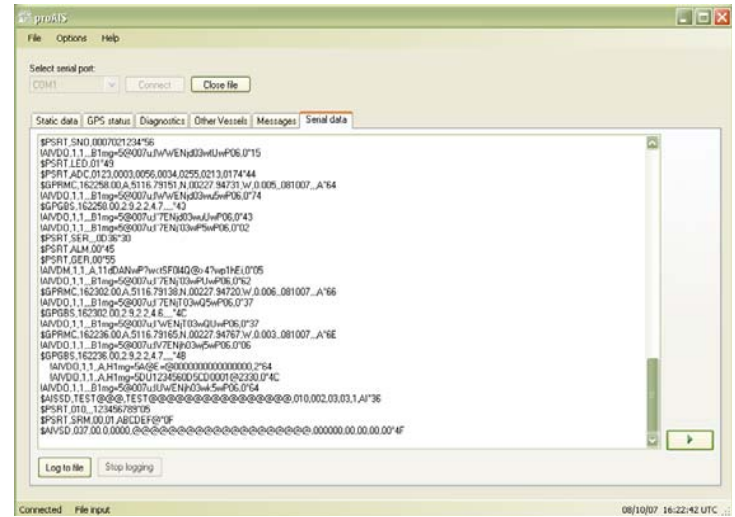

Figure 19 proAIS Serial data page

## 5.4 Indicator functions

The AIS transceiver includes four coloured indicators as shown in Figure 20. The state of the indicators provides information regarding the status of the AIS transceiver.

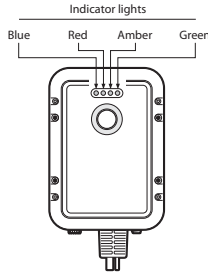

Figure 20 Indicator location on the AIS transceiver unit

The meaning of typical indicator configurations is shown in the table below and Figure 20 shows the orientation of the AIS transceiver.

	<p>The AIS transceiver is powered up, has a position fix and has transmitted at least one vessel information report.</p>
	<p>The AIS transceiver has detected a system error. The likely causes of this are detailed in the troubleshooting guide in section 6.</p>

	<p>When the switch function is configured to activate the silent mode feature and the switch has been depressed for more than two seconds, this combination of indicators will be illuminated to show that the transmitter is disabled.</p> <p>This arrangement of indicators will also be visible if the AIS transceiver has been configured for the blue indicator to signify received AIS messages. In this case the blue indicator will rapidly turn on and off as messages are received.</p>
	<p>The AIS transceiver is in 'transmit timeout' mode. This can be for a number of reasons:</p> <ul style="list-style-type: none"> <li>• The unit has only recently been powered on and is obtaining a position fix prior to transmitting its first vessel information report. (This process can take several minutes).</li> <li>• Position fix has been lost. The AIS transceiver will attempt to regain position fix for 30 minutes before entering an error state.</li> <li>• The AIS radio channels are exceptionally busy so there is currently no available timeslot for transmission.</li> <li>• The unit has been in silent mode and after deactivating silent mode this amber indicator will illuminate until the first AIS message has been sent</li> <li>• The AIS transceiver has been commanded by the local authority (via an AIS Basestation) to cease transmissions.</li> </ul>
	<p>When the switch function is configured to activate safety related messages and the switch has been depressed for more than two seconds the blue indicator will illuminate for 1 minute. It is not possible to send a safety related message at a rate of more than once per minute.</p>

# 6 Troubleshooting

Issue	Possible cause and remedy
No data is being received by the chart plotter	<ul style="list-style-type: none"> <li>• Check that the power supply is connected correctly.</li> <li>• Check that the power supply is a 12V supply.</li> <li>• Check that the connections to the chart plotter are correct.</li> </ul>
No indicators are illuminated	<ul style="list-style-type: none"> <li>• Check that the power supply is connected correctly.</li> <li>• Check that the power supply is a 12V supply.</li> </ul>
The Red 'error' indicator is illuminated	<ul style="list-style-type: none"> <li>• The unit may not have a valid MMSI. Check that the AIS transceiver is correctly configured with a valid MMSI.</li> <li>• The VHF antenna may be faulty. Please check the connection to the VHF antenna and that the VHF antenna is not damaged. The red indicator may illuminate briefly if the power supply is interrupted or the VHF antenna characteristics are briefly affected.</li> <li>• The GPS antenna may be faulty. Please check the connection to the GPS antenna and that the GPS antenna is not damaged.</li> <li>• The power supply is outside the allowable range. Check that the power supply is within the range 9.6V to 15.6V.</li> <li>• If none of the above correct the error condition please contact your dealer for advice.</li> </ul>

<p>My MMSI is being received by other vessels but my vessel name is not shown on their chart plotter or PC</p>	<ul style="list-style-type: none"> <li>• Some older AIS devices and chart plotters do not process the specific class B AIS message which provides the vessel name (message 24). This is not a fault of your AIS transceiver. Software upgrades are available for many older chart plotters which will correct this issue. The other vessel should update its AIS unit and/or chart plotting software to receive AIS message 24.</li> </ul>
--	--

If the guidance given in the table above does not rectify the problem you are experiencing, please contact your dealer for further assistance.

# 7 Specifications

Parameter	Value
Dimensions	215 x 150 x 45 mm (L x W x H)
Weight	685g (AIS transceiver unit only)
Power	DC (9.6V - 15.6V)
	Average power consumption 4W
	Peak current rating 2A
GPS Receiver (AIS Internal)	16 channel IEC 61108-1 compliant
Electrical Interfaces	RS232 38.4kBaud bi-directional
	RS422 NMEA 38.4kBaud bi-directional
Connectors	VHF antenna connector
	GPS antenna connector
	RS232/RS422/Power/External switch
VHF Transceiver	Transmitter x 1
	Receiver x 2 (One receiver time shared between AIS and DSC)
	Frequency: 156.025 to 162.025 MHz in 25 kHz steps
Output Power	33dBm $\pm$ 1.5 dB

Channel Bandwidth	25kHz
Channel Step	25kHz
Modulation Modes	25kHz GMSK (AIS, TX and RX)
	25kHz AFSK (DSC, RX only)
Bit rate	9600 b/s $\pm$ 50 ppm (GMSK)
	1200 b/s $\pm$ 30 ppm (FSK)
RX Sensitivity	Less than -107dBm at 20% PER
	Co-channel 10dB
	Adjacent channel 70dB
	IMD 65dB
	Blocking 84dB
Environmental	Water resistant to IPx7
	Operating temperature: -25°C to +55°C
	Tested to IEC 60945 'Protected' category
Indicators	Power, TX timeout, error, status
Operator Controls	Single switch configurable to enable either silent mode or safety related message functions

The em-trak B200 is an aid to navigation and must not be relied upon to provide accurate navigation information. AIS is not a replacement for vigilant human lookouts and other navigation aids such as Radar. The performance of the B200 may be seriously impaired if not installed as instructed in the user manual, or due to other factors such as weather and or nearby transmitting devices. Compatibility with other systems may vary and is reliant on the third party systems recognising the standard outputs from the B200. em-trak reserves the right to update and change these specifications at any time and without notice.



High Performance Maritime Products

[www.em-trak.com](http://www.em-trak.com)

**Head Office:**

em-trak Marine Electronics Limited  
Forum 3,  
Parkway, Solent Business Park,  
Whiteley, Fareham,  
Southampton PO15 7FH  
United Kingdom  
T +44 (0)1489 611662  
F +44 (0)1489 611612  
[enquiries@em-trak.com](mailto:enquiries@em-trak.com)

**Regional Office:**

em-trak Marine Electronics Limited  
470 Atlantic Avenue,  
4th floor,  
Boston,  
02210 United States  
T +1 617 273 8395  
F +1 617 273 8001  
[enquiries@em-trak.com](mailto:enquiries@em-trak.com)